

## NON-SELF-MAINTAINED DISCHARGE PLASMA TREATMENT OF AQUEOUS HEAVY-METAL SOLUTIONS

V. Ya. Chernyak, P. N. Tsybulev,  
S. V. Olszewski, and P. N. Voronin

UDC 533.9.01:535.375

*An electrochemical system is studied in which one electrode is in the vapor phase over a liquid surface and the other is under the liquid surface, and a non-self-maintained glow discharge initiated by a subsidiary discharge burns between the upper electrode and the liquid surface. It is shown that in this system ions of heavy metal compounds are released from solution within a relatively thin near-surface layer of the solution. Conditions are found under which the efficiency of plasma chemical extraction of metals from the solutions is several times higher in comparison with the electrochemical method.*

In recent years, studies of plasma-liquid contact (PLC) have attracted special attention in plasma physics. Physical and chemical processes that occur in a gas-liquid system and are induced by plasma are not only of scientific but also of technological interest [1-5]. A main characteristic of plasma generators in which PLC is realized is their operation at high pressures in the vapor-gas phase (from several mm Hg to atmospheric pressure and above), which leads to development of ionization- and superheat-induced instability in plasma [6-8]. Therefore, the plasma-liquid contact is almost always unstable, which makes investigation and use of such systems rather difficult.

It is known that one of the ways to suppress this type of instability of discharge plasma is to use an additional external ionizer [8], i.e., to substitute non-self-maintained discharges for self-maintained ones. In the present work a subsidiary discharge that burns in vapor over the liquid was used for stabilization of a non-self-maintained discharge plasma column and for expanding the PLC area [9].

**Experimental.** Schematic diagrams of experimental setups are shown in Fig. 1. Their main components are a cylindrical Pyrex housing 3 with a window 2 of molybdenum glass located between flanges 1 of Plexiglas; electrodes 7 and 8 used to maintain the non-self-maintained discharge, and electrodes 5 and 6, to maintain the subsidiary discharge. An electrode 8 of IKh18N10T steel is submerged in the liquid that fills the lower part of the casing. This electrode could function as an anode (when a positive potential was supplied to it) or a cathode (with a negative potential supplied). Electrodes 5-7 were in the vapor over the liquid layer. The electric-discharge supply system was intended to perform separate control of the non-self-maintained and subsidiary discharges. A probe 4 was used to measure the floating potential.

In the setup presented in Fig. 1a the PLC can be stabilized only at positive polarity of the submerged electrode, which substantially limited the efficiency of plasma in stimulation of chemical processes in the liquid. The setup shown in Fig. 1b allowed us to change the voltage polarity at the non-self-maintained discharge without marked disturbances of its external characteristics and the stability of the PLC. The main characteristic of this setup is that two parallel water-cooled hollow electrodes 5 and 6 were used to maintain the subsidiary self-maintained discharge, whose column was located parallel to the liquid surface.

We concentrated mainly on the axial and radial potential distributions in the plasma and liquid, and on the effect of concentrations of aqueous solutions of metal salts and alkali in them. Moreover, we studied the spectral composition of plasma radiation, the effect of pressure in the system on it, plasma-induced precipitation of metals from solutions, and the chemical composition of the resultant precipitates.

---

Taras Shevchenko University of Kiev, Ukraine; Institute of General and Inorganic Chemistry, National Academy of Sciences of Ukraine, Kiev, Ukraine. Translated from *Inzhenerno-Fizicheskii Zhurnal*, Vol. 70, No. 4, pp. 625-629, July-August, 1997. Original article submitted February 24, 1997.

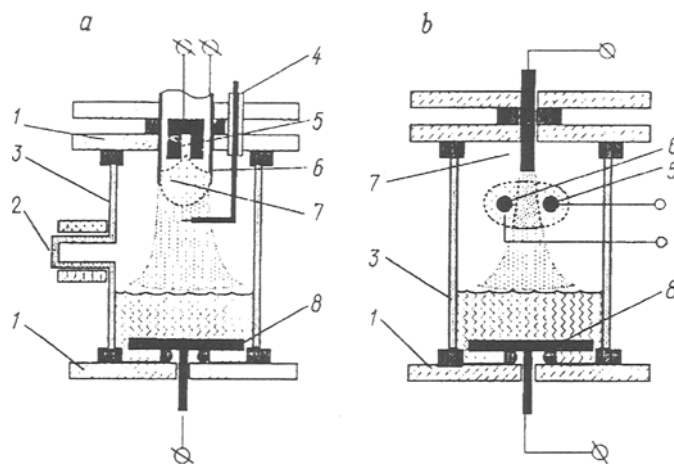

Fig. 1. Schematic diagrams of experimental setups with coaxial end subsidiary (a) and near-surface subsidiary (b) discharges.

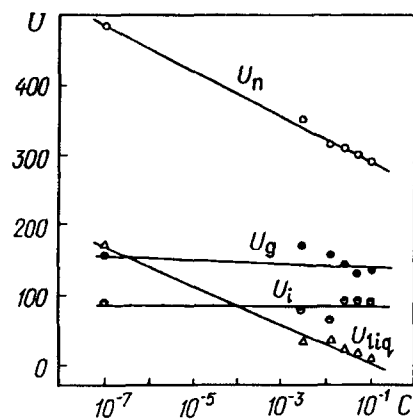

Fig. 2. Plot of voltage drop  $U$  (V) in system versus concentration of solution  $C$  (mole/liter).

The state of neutral components of the plasma was determined by analysis of optical spectra in the visible range with the use of a KSVU-23 optical complex. Atomic-adsorption and differential thermal analyses were used for chemical analysis of the solutions and precipitates. Aqueous solutions of NaOH,  $\text{Al}(\text{NO}_3)_3$ ,  $\text{Zn}(\text{NO}_3)_2$ , and  $\text{Pb}(\text{NO}_3)_2$  as well as distilled water were taken as initial solutions. The studies were carried out with fixed pressures in the system in the range 1–340 mm Hg.

**Results.** The studies have shown that concentrations of the solutions have a weak effect on the voltage drop across the plasma column ( $U_g$ ) and on the potential drop across the phase interface ( $U_i$ ). Meanwhile, the voltage drop across the liquid layer ( $U_{liq}$ ) and the voltage drop between the non-self-maintained discharge electrodes ( $U_n$ ) decreases following an exponential law as the concentrations of the solutions increase (Fig. 2).

The shape of the non-self-maintained discharge plasma column depends on the concentration of the solution and can be expressed as a truncated cone with the larger base on the interface in the case of low concentrations and with the smaller base on the interface at high concentrations.

In Fig. 3 one can see a family of radial distributions of the floating potential of a flat molybdenum probe at pressure  $P = 15$  mm Hg in the system,  $U_n = 450$  V, and a current of the non-self-maintained discharge  $I_n = 100$  mA. It can be seen that in the gas phase near the water surface the distribution of  $U_r$  is nonmonotonic. The systems with a solution are characterized by a monotonic behavior of  $U_r$  (curve 2, Fig. 3b). As the distance to the surface of submerged electrode 8 decreases, the floating potential gradient falls to zero (curves 5 in Fig. 3).

Thus, steam-water systems are characterized by the fact that  $U_r$  increases along the radius in the water (Fig. 3a, curves 3, 4) and in the near-surface gas layer up to a certain radius (curve 2, Fig. 3a). This can probably be explained by the higher mobility of positive charges in comparison with the mobility of negative charges (in water these can be  $\text{H}^+$  and  $\text{OH}^-$  ions). In the system with NaOH,  $U_r$  is not found to increase along the radius in

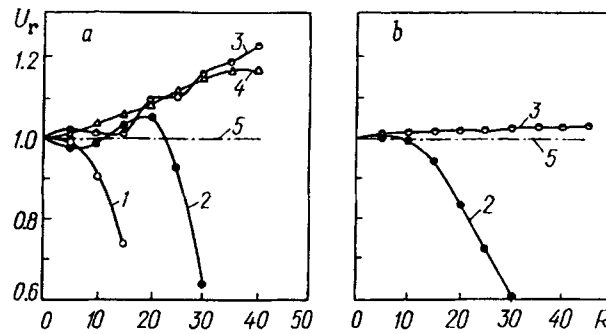

Fig. 3. Distribution of dimensionless floating potentials  $U_r$  over radius  $R$  in system with distilled water (a) and aqueous solution of 0.1 NaOH (b) at a 30 mm level of liquid over lower electrode in cross-sections parallel to interface at distances from the interface: 1) 35 mm; 2) 5 mm (in gas phase); 3) 5 mm; 4) 15 mm; 5) 30 mm (in liquid phase).  $R$ , mm.

the gas phase (curve 2, Fig. 3b) and in the solution  $U_r$  does not increase along the radius as much as it does in the gas (curve 3, Fig. 3b).

In the emission spectrum of plasma in contact with water we observed lines of atomic hydrogen ( $H_\alpha$ ,  $H_\beta$ ,  $H_\gamma$ ,  $H_\delta$ ), bands of the OH ( $A^2\Sigma^+ - X^2\Pi$ ) radical, and  $N_2$  ( $C^3\Pi - B^3\Pi$ ) molecules in the range 200–600 nm (designations as in [10, 11]). For  $N_2$  bands the curves of their relative intensity  $I_{rel}$  versus pressure of a vapor-gas mixture appear interesting (Fig. 4). It is remarkable that, first, in all the curves except curve 1, there are two maxima. Second, the relative maximum of  $I_{rel}$  increases in the pressure range 120–340 mm Hg as the vibrational quantum number of the upper level increases (curves 1-3).

The curves of the relative intensities of the nitrogen bands versus pressure can be explained qualitatively as follows. In the low pressure range the existence of a maximum is likely to be caused by the fact that as the nitrogen pressure increases, the concentration of nitrogen molecules and, accordingly, their emission intensity should increase; however, this is accompanied by a substantial decrease in the diameter of the plasma column. A sharp increase in the radiation intensity of molecular bands that is observed in the range of high pressures can be ascribed to initial pinching that results in an increase in the electron temperature and, accordingly, in the rate of excitation of molecules. However, pinching, in turn, indicates initial development of instability in plasma that leads eventually to collapse of the discharge and to a decrease in the intensity of the plasma column glow at pressures above 180 mm Hg.

This behavior indicates that in the region of low pressures the plasma electron temperature is almost constant and noticeably increases at high pressures. This conclusion correlates well with visualization of the behavior of the plasma column. While in the range of low pressures the discharge column seemed homogeneous, at pressures above 100 mm Hg a brightly glowing pinch caused by contraction of the discharge was observed. As the upper limit of the pressure range was approached, the pinch became unstable and was contracted to  $R < 1$  mm.

We also studied the effect of pressure in the system on the process of precipitation of metals from solutions subjected to plasma treatment. At all pressures of the vapor-gas mixture the exposure time and discharge current were maintained constant (600 sec and 100 mA, respectively). The pressure was controlled by decreasing the evacuation rate and varied between 1 and 250 mm Hg. The thickness of the aqueous solution of  $Pb(NO_3)_2$  over the surface of the lower electrode was 35 mm. The concentration of the initial solution was assumed to be 0.035 mol/liter.

In a solution subjected to plasma treatment intense precipitation takes place, and the region where it is initiated, is localized in the near-surface layer of the solution. Visible characteristics of the precipitation region changed as the pressure of the vapor-gase mixture grew. In the pressure range 1–18 mm Hg the precipitation region was a dingy-yellow film that covered the entire surface of the solution. The thickness of the film depended on pressure and constituted  $\sim 1$  mm at  $P = 1$  mm Hg and  $\sim 5$  mm at  $P = 18$  mm Hg. The dingy-yellow precipitate of amorphous lumps with a characteristic size of 3–8 mm slowly sank to the bottom. During exposure of the solution

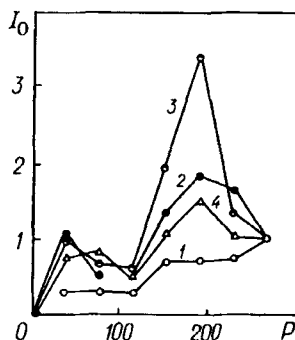

Fig. 4. Plot of relative intensity of bands of second positive nitrogen system ( $I_{rel}$ ) versus pressure ( $P$ ) for various vibrational transitions ( $v' - v''$ ): 1) (0-0); 2) (1-3); 3) (2-4); 4) (3-6).  $P$ , mm Hg.

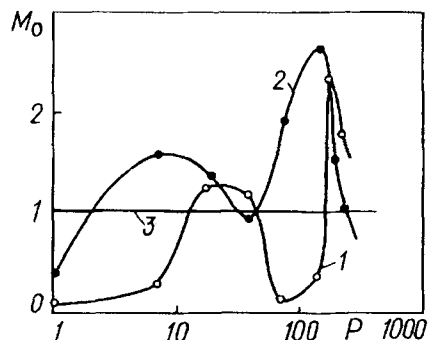

Fig. 5. Plot of relative mass of precipitated lead  $M_{rel}$  versus pressure in discharge chamber at concentration of initial solution of 0.035 mole/liter, duration of plasma treatment of 600 sec and non-self-maintained discharge currents: 1) 100 mA; 2) 200 mA; 3) theoretical yield calculated by Faraday's law.

to plasma the lumps were transformed into a loose dark-brown powder. The initially colorless solution became dingy-yellow. As the pressure increased to 144 mm Hg, the thickness of the near-surface layer of the solution in which precipitation occurred increased to 10 mm.

When the solution was treated by plasma in the pressure range 100–250 mm, the precipitate was white and flocculent. Floccs were also generated in the near-surface region, whose size was restricted by the area of visible plasma-solution contact. When they reached a characteristic size of 5–10 mm, they were separated from the interface and sank to the bottom.

After the solution treated by plasma was allowed to settle for 24 h, it became transparent but with a yellowish tint. It should be noted that the dark-brown color of the precipitate was almost independent of the plasma treatment.

The lead concentration in a solution treated by plasma was measured with the atomic adsorption method. With the measured quantities we obtained curves of the relative mass of the precipitated lead  $M_{rel}$  versus the pressure of the vapor-gas mixture in the discharge chamber (Fig. 5). In Fig. 5,  $M_{rel}$  is the ratio of the absolute mass of the precipitated lead determined by chemical analysis of the treated solution to the mass of the metal calculated by Faraday's law with known currents and exposure time.

As can be seen from Fig. 5, the curve of  $M_{rel}$  versus  $P$  is nonmonotonic. The curves have two maxima: one in the pressure range 10–30 mm Hg and the other in the range 150–200 mm Hg, which correlates well with the curve for the relative intensity of molecular nitrogen bands (Fig. 4). At  $I_n = 100$  mA in the pressure ranges 10–40 and 130–210 mm Hg and for  $I_n = 200$  mA in the pressure ranges 3–20 and 60–200 mm Hg, the current efficiency of the lead yield exceeds the theoretical value calculated by Faraday's law [12] (the valence of the lead was assumed to be 2). Similar results were obtained for precipitation of aluminium and zinc.

The differential thermal study of the composition of the precipitates produced by non-self-maintained discharge plasma treatment of aqueous solutions of aluminum, zinc, and lead nitrates has shown that the precipitates consist mainly of hydroxides of the corresponding metals and that the precipitates containing lead also contain lead oxide.

## CONCLUSIONS

1. It is shown that in the discharge plasma-liquid system a nonmonotonic radial distribution of the floating plasma potential is observed near the phase interface.

2. It is found that in the discharge plasma-aqueous solution of salts, precipitation occurs within a relatively thin (1–10 mm) near-surface layer of the solution, and the thickness of the layer increases as the pressure in the system grows.

3. Conditions are found under which precipitation of metals from solutions exposed to non-self-maintained discharge plasma exceeds their yield calculated by Faraday's law.

## NOTATION

$C$ , concentration of solution, mole/liter;  $I_n$ , non-self-maintained discharge current;  $I_{rel}$ , relative intensity of bands in spectra of gases;  $M_{rel}$ , relative mass of metal precipitated from solution;  $P$ , pressure in system, mm Hg;  $R$ , radius, mm;  $U_g$ , voltage drop at non-self-maintained discharge in gas phase, V;  $U_{liq}$ , voltage drop in liquid layer, V;  $U_i$ , voltage drop at vapor–liquid interface, V;  $U_r$ , dimensionless discharge distribution of floating potential over radius;  $U_n$ , voltage drop between electrodes of non-self-maintained discharge, V.

## REFERENCES

1. B. M. Penetrante, in: *Contributed Papers of ESCAMPIG 96, Poprad, Slovakia (1996)*, pp. XLIX-LI.
2. M. Cernak, P. Sunka, M. Clupek, and V. Babicky, in: *Contributed Papers of ESCAMPIG 96, Poprad, Slovakia (1996)*, pp. LVII-LX.
3. D. Moussa and J. L. Brisset, in: *Contributed Papers of Int. Symp. on High-Pressure Low-Temperature Plasma Chemistry, Milovy, Czech Republic (1996)*, pp. 165-169.
4. F. Frederic and J. L. Brisset, in: *Contributed Papers of Int. Symp. on High-Pressure Low-Temperature Plasma Chemistry, Milovy, Czech Republic (1996)*, pp. 87-91.
5. A. V. Kravchenko, O. A. Podgornyi, V. V. Tsarenko, A. F. Nesterenko, Yu. A. Rakhmanin, and V. S. Kublanovskii, *Khim. Tekhnol. Vody*, 17, No. 5, 549-553 (1995).
6. F. M. Gaisin, E. E. Son, and Yu. I. Shakirov, *Volume Discharge Between Solid and Liquid Electrodes in a Vapor–Gas Medium [in Russian]*, Moscow (1990).
7. E. V. Martych and V. S. Sidorenko, in: *Contributed Papers of Int. Symp. on High Pressure Low Temperature Plasma Chemistry, Milovy, Czech Republic (1996)*, p. 281.
8. Yu. P. Raizer, *Fundamentals of Modern Physics of Gas Discharges [in Russian]*, Moscow (1980).
9. V. Ya. Chernyak, P. N. Tsybulev, S. V. Olszewski, P. N. Voronin, and M. A. Evstigneev, in: *Contributed Papers of Int. Symp. on High-Pressure Low-Temperature Plasma Chemistry, Milovy, Czech Republic (1996)*, pp. 235-239.
10. G. A. Kasabov and V. V. Eliseev, *Spectroscopic Tables for Low-Temperature Plasma [in Russian]*, Moscow (1973).
11. K. P. Hübner and G. Gersberg, *Constants of Biatomic Molecules [Russian translation]*, Moscow (1984), Vol. 2.
12. W. Schreter, K.-H. Lautenschleger, H. Birbrak, et al., *Chemistry (Handbook) [Russian translation]*, Moscow (1989).